

# Digital Dimmer

Part#: 21005

## INSTALLATION INSTRUCTIONS

### PARTS/TOOLS NEEDED:

				
Dimmer Switch	Bezel & Knob (optional)	Mounting Screws	Wire Nuts	Power Drill

### IMPORTANT SAFETY INSTRUCTIONS. READ CAREFULLY FOR YOUR PROTECTION AND SAVE ALL INSTRUCTIONS.

- Disconnect power before installing, adding or changing any component.
- To avoid a hazard to children, account for all parts and destroy all packing materials.
- It is recommended that fuse protection be added to the positive (+) input.

1. Determine the installation location for your switch and cut a 1-1/2" x 2" hole using a drywall saw.



2. Using wire nuts attached the units' power to the wires labeled input and attach the output side to your selected light fixture. (figure 1)



3. Feed wires back through the hole and screw the switch in place using the screws provided.



4. To attach the bezel, first remove the black knob. Slide bezel onto switch and install new knob.



**Figure 1:** Wire the switch based on the wiring diagram below.

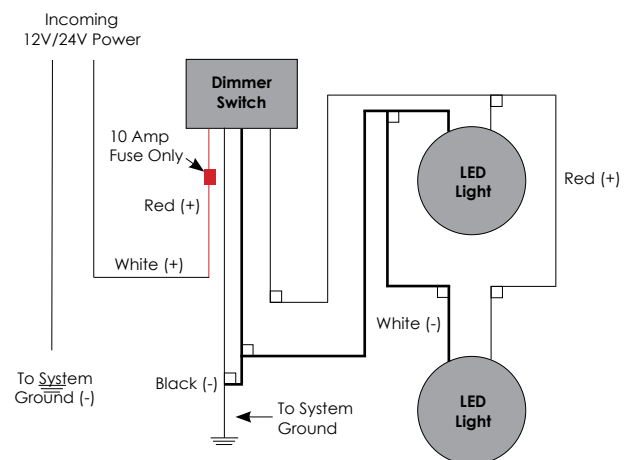

3030 Corporate Grove Dr.  
Hudsonville, MI 49426  
Phone: 616.396.1355  
[itc-us.com](http://itc-us.com)

For warranty information please visit [www.itc-us.com/warranty-return-policy](http://www.itc-us.com/warranty-return-policy)  
DOC #: 710-00097 · Rev B · 11/16/2022